



**VALVE REGULATED
LEAD ACID BATTERY (V.R.L.A.)**



**ABSORBED GLASS MAT
TECHNOLOGY (A.G.M.)**



**10 YEAR DESIGN FOR UPS AND
STANDBY APPLICATIONS**



Features

- Gas recombination greater than 99%.
- Operates at a low internal pressure.
- Never needs watering, minimal maintenance.
- 99.7% pure lead calcium grids.
- Shock absorbent thick wall construction.
- Cold forged non-porous terminal bushings, eliminate post leakage.
- Thermally welded case to cover bond, eliminates both acid and electrical leaks.
- Over-sized, through the partition inter-cell welds provide low resistance connections, with minimal power loss.
- Each cell has a low pressure safety release venting system, recognized per U.L. 924.
- Measured high vacuum acid fill, reduces electrical variability between cells.
- 100% recyclable materials.

Options

- The TC-12120S battery has a flame retardant polypropylene case and cover compliant with UL 1778; with an oxygen index greater than 28%.
- Terminal covers and custom inter-connecting battery cables.

Specifications

Cells per unit	6
Nominal voltage	12
Terminal type	1/4" Stud
Maximum discharge current	700 amps
Short circuit current	4182 amps
Impedance @ 77°F 25°C	3.30 milliohms
Weight lbs / kgs	81.8 / 37.1
Electrolyte (S.G.)	1.300
Capacity @ 77°F (25°C) to 1.75 V.P.C.	109.6 AH (20 hrs) 96.0 AH (8 hrs)
Ideal operating temperature range	+68°F (+20°C) to +77°F (+25°C)
Extended operating temperature range	Discharge: -40°F (-40°C) to +140°F (+60°C) Charge: -40°F (-40°C) to +122°F (+50°C)
Float Voltage	13.5 to 13.8 @ 77°F (25°C)
Maximum charging current	C/4 amperes at 100% discharge Unlimited at partial discharge.
AC ripple from charging source	1.5% peak to peak of float charge voltage
Storage	6 months at 77°F (25°C)

No transport restrictions

- Surface transport. Classified as non-hazardous material as relates to DOT-CFR Title 49 part 171-189.
- Maritime transport. Non hazardous as per IMDG amendment 27.
- Air transport. Complies with IATA / ICAO, special provision A67.

DISCHARGE SPECIFICATIONS

Constant power ratings, Watts per battery @ 77°F (25°C) in minutes										
Final V.P.C.	5	10	15	20	30	40	45	50	60	90
1.60	3933	2918	2251	1842	1365	1095	1009	923	803	585
1.67	3800	2863	2227	1825	1355	1088	1003	918	799	584
1.70	3742	2842	2212	1815	1350	1085	1000	916	798	580
1.75	3548	2675	2132	1780	1337	1075	991	908	791	579

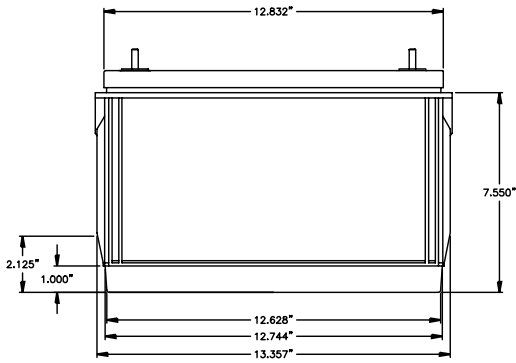

FRONT VIEW

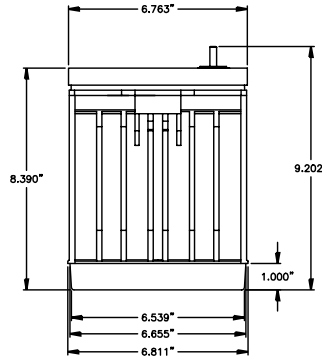

END VIEW

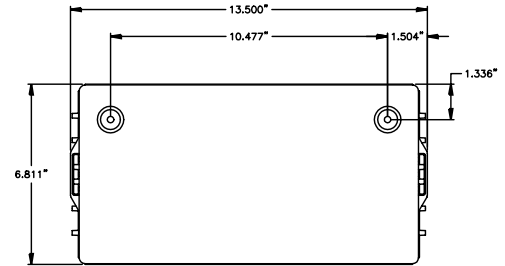

TOP VIEW

POWER BATTERY offers an extensive line of pre-wired and fused battery cabinets complete with UL and CUL approval. Standard and custom DC voltages complete with breakers and chargers are available.



Battery Cabinet Systems (pre-wired with PRC/TC-12120S batteries)					
Battery cabinet model	Maximum # of batteries	Dimensions			
		inches / millimeters			Weight lbs / kgs
		W	D	H	
KS5	2	15.0/381	25.0/635	15.75/400	211/95.9
KS6	4	16.0/406	34.5/876	17.75/451	406/184.5
KS7	8	16.0/406	34.5/876	37.25/946	812/369.1
CR1	12	24.0/610	32.5/826	43.0/1092	1254/570
CR3	20	40.0/1016	32.5/826	43.0/1092	1982/900.9
CR6	30	40.0/1016	32.5/826	60.0/1524	2926/1330
CR4	40	40.0/1016	32.5/826	77.0/1956	3870/1759

Constant current ratings, Amperes @ 77°F (25°C) in hours

Final V.P.C.	1	2	3	4	5	6	8	10	12	24
1.75	66.7	38.8	28.2	22.1	18.2	15.5	12.0	9.80	8.37	4.51
1.80	65.7	38.4	27.9	21.7	17.9	15.3	11.9	9.75	8.29	4.46
1.85	63.1	37.3	26.9	21.0	17.3	14.8	11.5	9.42	8.01	4.30
1.90	58.0	34.8	25.3	19.8	16.3	13.9	10.7	8.70	7.33	3.97

U.S.A.
Power Battery Company, Inc.
25 McLean Blvd.
Paterson, N.J. 07514-1507
Phone: (973) 523-8630
Fax: (973) 523-3023
E-mail: sales@powbat.com
Website www.powerbattery.com

CANADA
Power Battery (Iberville) Ltd.
770 Thomas Ave.
Iberville, Québec, J2X 5E7
Phone: (450) 346-3273
Fax: (450) 346-8003
E-mail: powerbat@sympatico.ca
Website: www.powerbattery.com

UK
Power Batteries Ltd.
Premier Way, Abbey Park Industrial Estate
Romsey, Hampshire, SO51 9AQ
Phone: +44 (0)1794 835900
Fax: +44 (0)1794 835910
E-mail: sales@powbat.co.uk
Website: www.powbat.co.uk

ITALY
Power Battery Srl
Via Locatelli 105
20046 Biassono MI - ITALY
Phone: +(39) 039 2324571
Fax: +(39) 039 2499200
E-mail: calberti@powbat.it
Website: www.powbat.it

CHINA
Power Battery (PACIFIC RIM) Ltd.
Unit 1, 23/floor, Wealthy Plaza
138 Sau Kei Wan Road
Sai Wan Ho, Hong Kong
Phone: ++(852) 2-560-2222
Fax: ++(852) 2-967-8157
E-mail: bplhk@netvigator.com
Website: www.powerbattery.com