

HC 1225W

12V 25W

HC 1225W is specially designed for high efficient discharge application. Its invisible terminal can be inserted PC board directly. HC series battery can serve more than 260 cycles at 100% discharge in cycle service, or three to five years in standby service.



Specification

Cells Per Unit	6
Voltage Per Unit	12
Capacity	25W @ 15minute-rate to 1.67V per cell @25 °C(77°F)
Weight	Approx. 2.40kg(5.29 lbs)
Maximum Discharge Current	60A(5sec)
Internal Resistance	Approx. 30mΩ
Operating Temperature Range	Discharge: -20°C~50°C(-4°F~122°F) Charge: 0°C~40°C(32°F~104°F) Storage: -20°C~40°C(-4°F~104°F)
Nominal Operating Temperature Range	25°C±3°C(77°F±5°F)
Float Charging Voltage	13.5 to 13.8 VDC/unit Average at 25°C(77°F)
Recommended Maximum Charging Current Limit	2.5A
Equalization and Cycle Service	14.4 to 15.0 VDC/unit Average at 25°C(77°F)
Self Discharge	CSB Batteries can be stored for more than 6 months at 25°C(77°F). Please charge batteries before using. For higher temperatures the time interval will be shorter.
Terminal	Faston Tab 187/250
Container Material	-ABS (UL94-HB)*Flammability resistance of UL94-V2 can be available upon request.



CSB-manufactured batteries are UL-recognized components under UL924 as well as certified by ISO 9001 and ISO 14001.

Dimensions

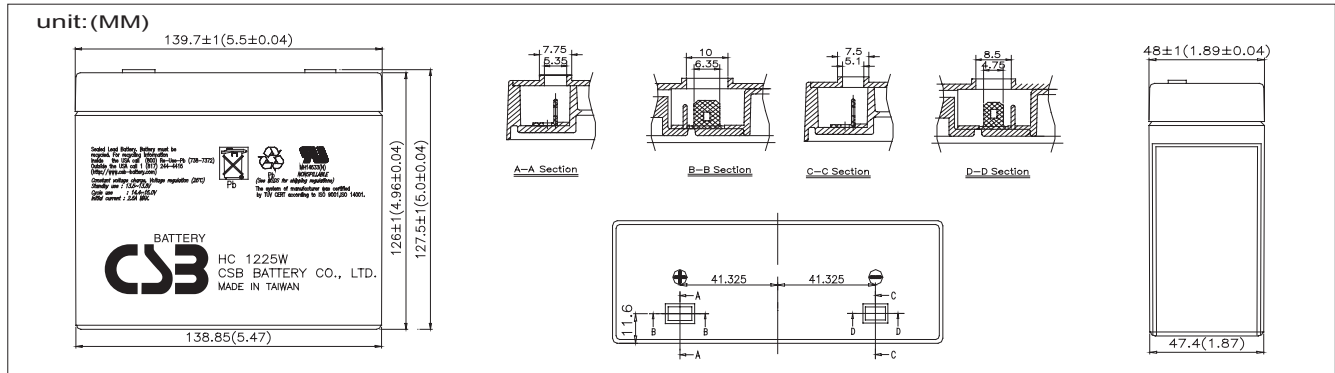

Constant Current Discharge Characteristics Unit:A (25°C, 77°F)

F.V/Time	2MIN	4MIN	6MIN	8MIN	10MIN	15MIN	20MIN	30MIN	60MIN	90MIN
1.60V	47.8	35.3	28.3	23.0	18.1	13.3	11.9	9.08	5.28	3.21
1.67V	44.1	33.3	26.6	21.7	17.3	13.0	11.7	8.91	5.12	3.06
1.70V	42.5	32.4	25.9	21.1	17.0	12.9	11.6	8.83	5.05	2.99
1.75V	40.0	30.6	24.5	20.0	16.2	12.6	11.3	8.67	5.03	2.84
1.80V	37.6	28.8	23.0	18.9	15.4	12.3	11.0	8.50	5.00	2.68
1.85V	35.1	26.9	21.5	17.8	14.6	11.9	10.7	8.34	4.98	2.53

Constant Power Discharge Characteristics Unit:W (25°C, 77°F)

F.V/Time	2MIN	4MIN	6MIN	8MIN	10MIN	15MIN	20MIN	30MIN	60MIN	90MIN
1.60V	574	423	339	276	217	160	143	109	63.4	38.5
1.67V	529	399	319	260	208	157	140	107	61.4	36.7
1.70V	510	389	311	253	204	155	139	106	60.6	35.9
1.75V	481	367	294	240	195	151	136	104	60.3	34.0
1.80V	451	345	276	227	185	147	132	102	60.0	32.1
1.85V	422	323	259	214	176	143	129	100	59.7	30.2

- All mentioned values are average values.
- Low rate discharge mode (over 90 min.) is not recommended.

Trickle (or Float) Service Life

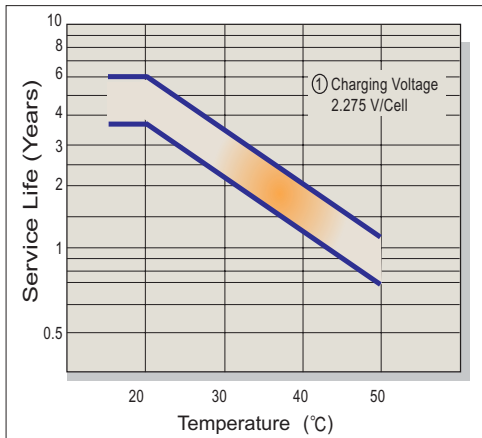

Capacity Retention Characteristic

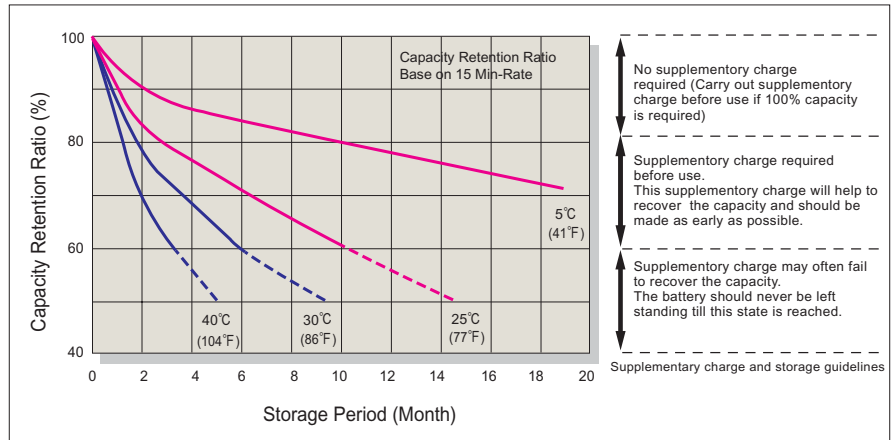

Battery Voltage and Charge Time for Standby Use

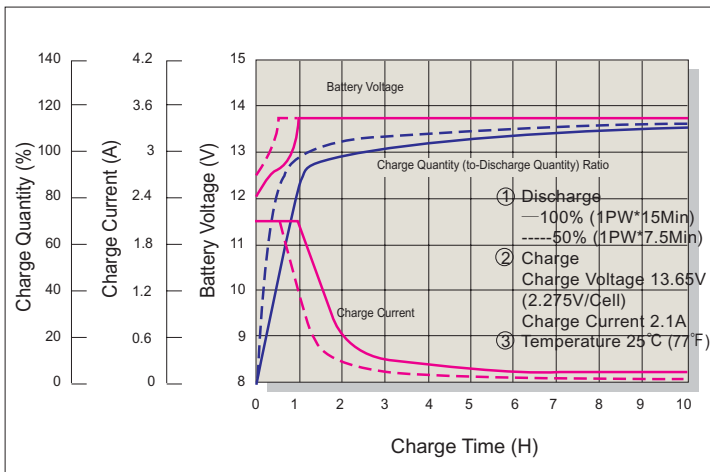

Cycle Service Life

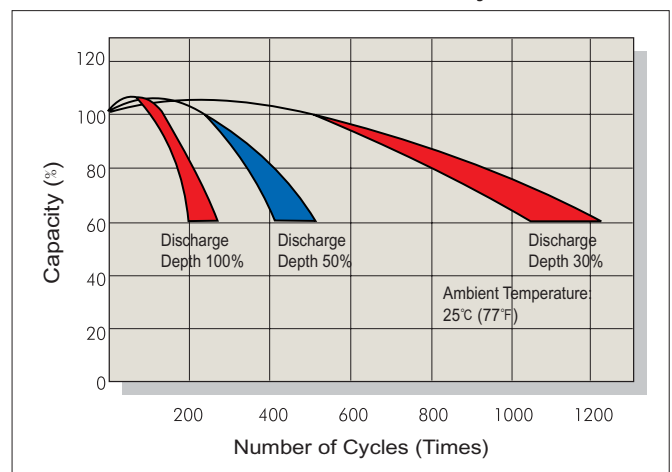

Battery Voltage and Charge Time for Cycle Use

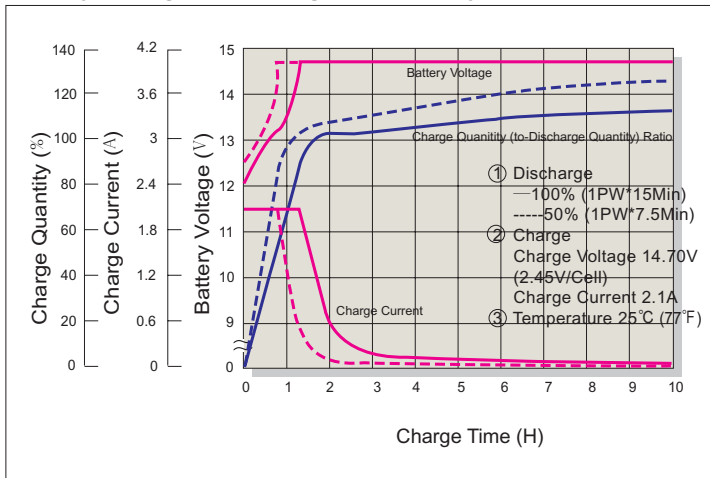

Terminal Voltage (V) and Discharge Time (25°C 77°F)

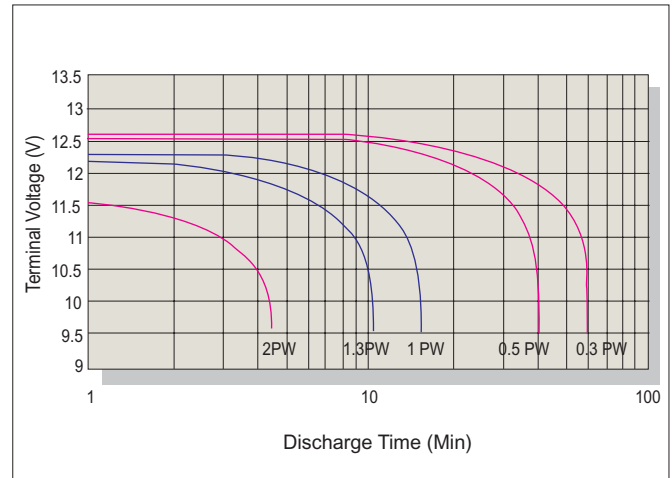

Charging Procedures

Application	Charge Voltage (V/Cell)			Max. Charge Current
	Temperature	Set Point	Allowable Range	
Cycle Use	25°C (77°F)	2.45	2.40~2.50	0.3C
Standby	25°C (77°F)	2.275	2.25~2.30	

Discharge Current VS. Discharge Voltage

Final Discharge Voltage V/Cell	1.75	1.70	1.55	1.30
Discharge Current (A)	0.2C>(A)	0.2C<(A)<0.5C	0.5C<(A)<1.0C	(A)>1.0C