

10-322

Micro ARE SERIES

For utility and telecommunications applications

- Microprocessor Controlled
- 24, 48 and 130-Volt Models
- 6 to 50 Amperes Output
- High Efficiency and Power Factor
- Single-Phase, Controlled Ferroresonant
- Digital Controls
- Low Electrical Noise
- Inherently Safe Design
- Low Maintenance
- Temperature Compensation



Micro ARE SERIES FLOAT RECTIFIERS

Controlled ferroresonant float rectifiers have many inherent advantages...voltage regulation, short circuit protection, low operating costs (a combination of high efficiency and high power factor), easy maintenance and high reliability.

The *Micro ARE* Series of float rectifiers combines these inherent advantages with advanced rectifier, control and filter circuitry, and user-oriented packaging. Designed specifically for utility and communication applications, the *Micro ARE* Series rectifiers are easily adjusted to meet your specific operating requirements and will provide years of low maintenance service.

INPUT

Transformers are dual wound for either 120, 208, 240 volts (+10 percent, -12 percent) or for 480 volts, single phase, 60 Hz +/- 3Hz. ARE-M13050 is dual wound for 208, 240, and 480 volts.

REGULATION

DC voltage is maintained within +/-0.5 percent at any load from no load to full load with +10 percent, -12 percent variation (or ANSI standard ranges) in the AC input voltage while floating rated number of cells.

Control is accomplished with a single microprocessor-control board and can operate with or without a battery.

During operation, the maximum output voltage transient does not exceed 5 percent of the initial steady-state voltage for sudden load changes between 10 percent and 90 percent of rated output. Recovery takes less than 300 milliseconds. Operation without a battery is stable under all conditions of line and load (within stated limits).

Turn-on under all conditions of line and load has a "soft-start" characteristic without overshoot.

REGULATION CURVE

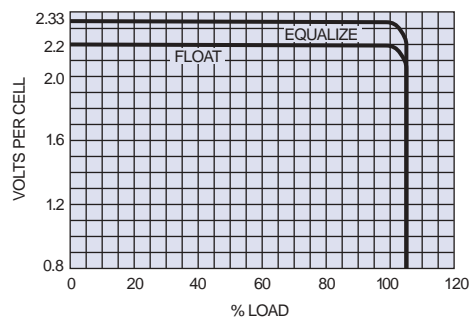

ELECTRICAL NOISE

For 24 and 48-volt models, the filtering provided produces a ripple level of less than 30 millivolts rms with electrical noise less than 22 Brnc measured on a battery with an eight-hour capacity rating of four times the rectifier current rating.

For 130-volt models, the filtering provided produces a ripple level of less than 30 millivolts rms when connected to a battery with an eight-hour capacity rating of four times the rectifier current rating.

The total dynamic response of the control circuitry permits all *Micro ARE* rectifiers to operate as power supplies with the optional battery eliminator.

EFFICIENCY AND POWER FACTOR

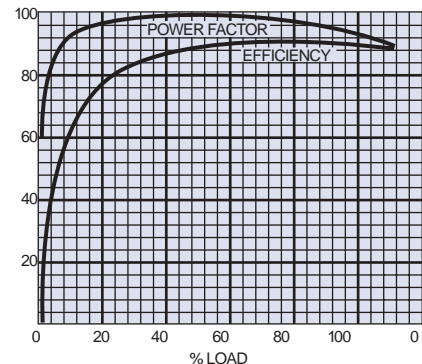

PRINCIPLES OF CONTROLLED FERRORESONANT OPERATION

The conventional ferroresonant transformer has inherently good regulation of output voltage against wide variations of input voltage. Its high reactance provides protection against overload and short circuit of the output. The output voltage does vary with changes in load and frequency. The output winding is on the same leg of the core as the resonant winding, and the resonant capacitor acts to maintain this core section at a high level of saturation, resulting in a constant voltage. To provide a precise constant voltage, it is necessary to control this level of core saturation. This is accomplished in the controlled ferro by shunting the resonant circuit with a switching device in series with an inductor. As shown in the block diagram, the unique *Micro ARE* circuit senses the start of the resonant capacitor charge cycle and switches the thyristor on to interrupt the cycle. The point of interruption is delayed by a signal fed back from the output to allow the voltage to rise to the preset level. In the event the current exceeds a preset level, the signal from the shunt overrides the voltage regulator to limit current; thus, precise control of voltage and current is maintained. If a fault occurs allowing a higher voltage to develop on the output, a sensing circuit causes the AC input breaker to shut down the charger.

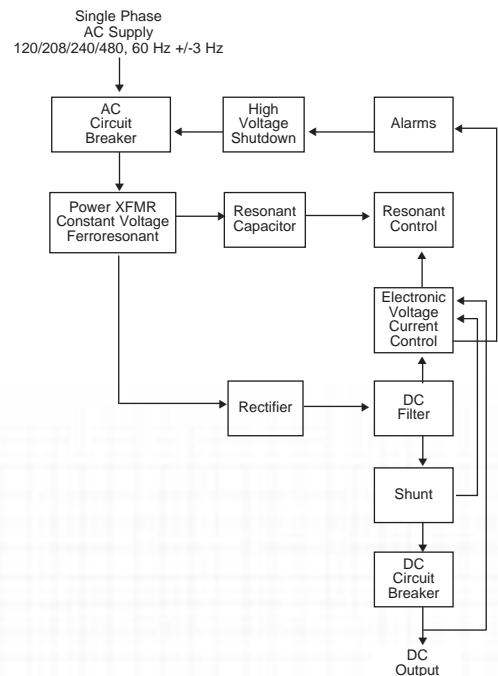

CURRENT LIMITING CIRCUIT

The current limiting circuit is factory set at 110 percent of rated DC output but can be adjusted down to 80 percent and up to 110 percent.

FLOAT AND EQUALIZE VOLTAGES

To accommodate different battery types, both the float and the equalize voltages are continuously adjustable (no taps) over the nominal voltage range (24-volt models: 24-29VDC; 48-volt models: 48-59VDC; 130-volt models: 120-147VDC). 24, 48 and 130-volt models can be equipped with an optional float-voltage sensor which can be connected up to 20 ft (6.1 m), from charger.

The temperature compensation circuitry will correct both the float and equalize voltages by 2.0 mV per degree F per cell [added for temperatures below 77F (25C) and subtracted for temperatures above 77F (25C)].

CIRCUIT PROTECTION

A two-pole shunt-trip AC circuit breaker is provided for input protection. A two-pole DC circuit breaker is provided in the output.

An AC power failure alarm relay provides Form C contacts, which operate in the event of an AC failure.

AMBIENT OPERATING TEMPERATURES

All *Micro* ARE rectifiers will operate at 110 percent of rated DC output, continuously in temperatures from 32F to 122F (0C to 50C) up to an altitude of 3,300 ft (1,000 m). De-rating of 3.6F (2C) for every 990 ft (300 m) over 3,300 ft (1,000 m) above sea level. These units can be safely stored for up to one year at temperatures ranging from -40F to 185F (-40C to 85C).

BATTERY ELIMINATOR OPERATION

All *Micro* ARE rectifiers will operate as a power supply without a battery at the following ripple levels:

- 24 and 48-volt models less than 30 millivolts rms
- 130-volt models less than 100 millivolts rms

MECHANICAL FEATURES

- Door opens approximately 90 degrees for easy access to interior
- The control board is mounted on the rear of the door for easy access
- The interface board is mounted behind the door for easy access
- Serviceable components are accessible and removable from the front
- Input and output connections are easily accessible
- Knockouts for cables are provided
- Clear space is provided in floor area for bottom entrance
- Cabinets can be relay rack, wall or floor mounted
- Cabinet has durable baked epoxy powder finish

STANDARD EQUIPMENT

- High-input voltage shutdown
- Redundant high-output voltage shutdown
- Digital display, 2 line by 20 characters, shows voltage and current in normal operation at one percent accuracy
- Float and equalize settings are adjusted via keypad
- AC power failure alarm relay with one set form C contacts
- Rectifier failure alarm relay with one set form C contacts
- High Voltage Shutdown failure alarm with one set form C contacts
- Red and Green LEDs display status of charger. Alarms are indicated on the digital display
- No-charge alarm—with load sharing circuit
- 0 to 150 hour equalize timer
- Ground fault detection alarm
- High and low-voltage alarm
- High DC voltage alarm
- Low DC voltage alarm
- Alarms have adjustable time delay, 1-15 seconds

OPTIONAL EQUIPMENT

- Blocking diode
- Lightning protection device
- Alarm board with individual form C contacts for the summary, GND +, GND -, LVA, HVA, and NCA relays
- Remote temperature probe
- AC input protection (MOVs)
- High capacity DC breaker
- Export packaging
- Drip top
- 50 Hz AC input
- Special voltages

TYPICAL CABINET DIMENSIONS

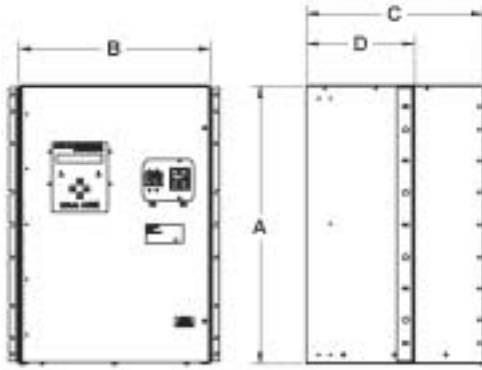

Cabinet	A	B	C	D
12	12.25 in 311 mm	17 in 432 mm	15 in 381 mm	6 in 152 mm
24	24.5 in 622 mm	17 in 432 mm	15 in 381 mm	6 in 152 mm
30	30 in 762 mm	20.5 in 521 mm	19 in 483 mm	11.6 in 295 mm

- 17 in (432 mm) wide cabinets can be used in 19 in (483 mm), 23 in (584 mm) or 30 in (762 mm) relay racks.
- 20.5 in (521 mm) wide cabinets can be used in 23 in (584 mm) or 30 in (762 mm) racks only.

- Rack angles mount at rear for wall mounting.
- Floor brackets are available for all models instead of relay rack mounting angles when ordered with charger.

24-volt output

Model	Input volts	AC amps	DC amps	Cabinet	Recommended DC cable size AWG	Circuit breaker DC	Approx. ship. wt.	
							lb	kg
ARE-M2406	120/208/240	2/1.1/1	6	12	14	10	65	30
ARE-M2412	120/208/240	4/2.3/2	12	12	10	20	72	33

48-volt output

Model	Input volts	AC amps	DC amps	Cabinet	Recommended DC cable size AWG	Circuit breaker DC	Approx. ship. wt.	
							lb	kg
ARE-M4806	120/208/240	4/2.3/2	6	12	14	10	72	33
ARE-M4812	120/208/240	7/4/3.5	12	12	10	20	95	43

130-volt output

Model	Input volts	AC amps	DC amps	Cabinet	Recommended DC cable size AWG	Circuit breaker DC	Approx. ship. wt.	
							lb	kg
ARE-M13006	120/208/240	8.5/5/4	6	12	14	10	100	46
ARE-M13012	120/208/240	18/10/9	12	24	10	20	170	77
ARE-M13012	480	5	12	24	10	20	170	77
ARE-M13016	120/208/240	22/13/11	16	24	10	20	185	84
ARE-M13016	480	6	16	24	10	20	185	84
ARE-M13025	120/208/240	35/20/17	25	30	8	40	325	148
ARE-M13025	480	8.5	25	30	8	40	325	148
ARE-M13035	120/208/240	50/29/25	35	30	8	50	460	209
ARE-M13035	480	12.5	35	30	8	50	460	209
ARE-M13050	208/240/480	40/25/17.5	50	30	4	70	600	273

C&D TECHNOLOGIES, INC.

POWERCOM DIVISION

1400 Union Meeting Road
P.O. Box 3053 • Blue Bell, PA 19422-0858
(215) 619-2700 • Fax (215) 619-7899 • (800) 543-8630
powercom@cdtechno.com
www.cdtechno.com

Any data, descriptions or specifications presented herein are subject to revision by C&D Technologies, Inc. without notice. While such information is believed to be accurate as indicated herein, C&D Technologies, Inc. makes no warranty and hereby disclaims all warranties, express or implied, with regard to the accuracy or completeness of such information. Further, because the product(s) featured herein may be used under conditions beyond its control, C&D Technologies, Inc. hereby disclaims all warranties, either express or implied, concerning the fitness or suitability of such product(s) for any particular use or in any specific application or arising from any course of dealing or usage of trade. The user is solely responsible for determining the suitability of the product(s) featured herein for user's intended purpose and in user's specific application.